

TYPE K II N

TECHNISCHE DATEN

der Universal Doppelschauligen
Misch- und Knetmaschinen

TECHNICAL DATA

of the Universal Double Arm Mixing
and Kneading Machines

CARACTÉRISTIQUES TECHNIQUES

des Mélangeurs-Malaxeurs
Universels à 2 Hélices

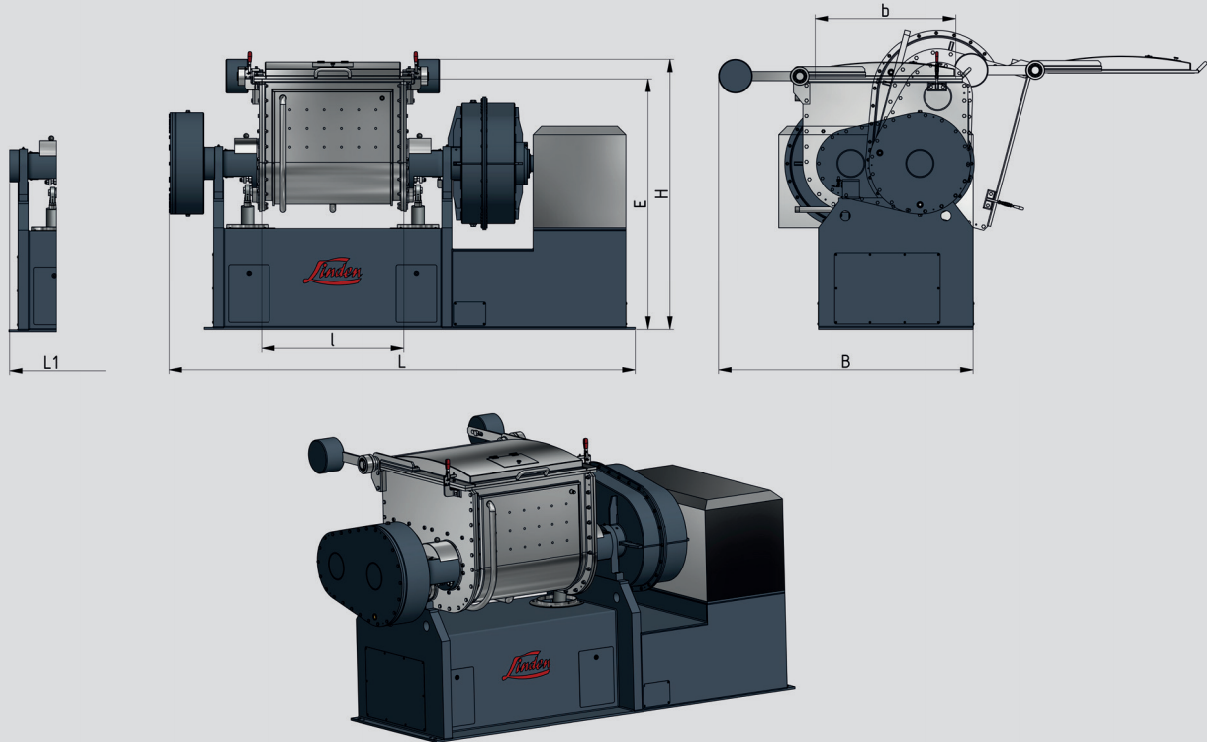

Type	Inhalt (l) Capacity (l) Capacité (l)		Kraftbedarf (durchschnittlich) kW Power Consumption (normally) kW Puissance Admise (en moyenne) kW	Abmessungen in mm (unverbindlich) Measurements in mm (without obligation) Dimensions en mm (sans engagement)									
	Nutz Working Utile	Total Total Totale		A	B	E	H	L	L ₁	b	l		
K II N 10	8	15	3,0 – 10,0	735	660	1100	1180	1380	1390	280	280		
K II N 20	20	33	3,7 – 11,0	715	950	1130	1210	1560	1560	360	350		
K II N 35	30	45	7,5 – 15,0	705	1020	1130	1210	1685	1685	400	400		
K II N 60	53	98	9,5 – 18,5	490	1165	1150	1230	1905	1905	520	430		
K II N 80	85	144	11,0 – 22,0	490	1225	1150	1230	2055	2055	580	576		
K II N 100	98	166	13,0 – 22,0	540	1225	1200	1290	2300	2300	620	620		
K II N 150	134	212	18,5 – 30,0	570	1230	1270	1350	2530	2550	648	700		
K II N 200	178	270	18,5 – 67,0	520	1410	1300	1380	2555	2605	756	700		
K II N 250	250	400	25,0 – 75,0	520	1410	1300	1380	2855	2905	832	840		
K II N 300	300	475	33,0 – 90,0	570	1500	1480	1500	3100	3100	900	900		
K II N 450	435	930	54,0 – 132,0	620	1625	1575	1675	3405	3455	960	1000		
K II N 600	550	760	75,0 – 160,0	650	1715	1650	1750	3525	3575	1050	1100		
K II N 800	770	1430	99,0 – 180,0	750	1820	1790	1890	3590	3640	1140	1250		
K II N 1000	1000	1380	110,0 – 200,0	950	1940	1860	1960	3760	3810	1260	1300		

Der Kraftbedarf richtet sich nach dem Einsatzfall, dem Mischgut, dem spezifischen Gewicht, der Viskosität usw. Konstruktionsänderungen vorbehalten.

The necessary power consumption depends on application, mixing material, specific gravity, viscosity etc. The right is reserved to make changes in design without prior notice.

La puissance admise nécessaire dépendra de l'utilisation, du matériau à mélanger, du poids spécifique, de la viscosité etc. Droits de modification de construction réservés.

HERMANN LINDEN MASCHINENFABRIK GmbH & Co. KG

Hauptstraße 123 D-51709 Marienheide
Tel.: +49(0)2264 4591-0 Fax: +49(0)2264 8715
info@linden-kneter.de www.linden-kneter.de